



Read this document carefully before using this device. The guarantee will be expired by damaging of the device if you don't attend to the directions in the user manual. Also we don't accept any compensations for personal injury, material damage or capital disadvantages.

## ENDA ATSP4 MULTI FUNCTIONAL ANALOG TIMER

Thank you for choosing ENDA ATSP4 Multi Functional Analog Timer

- \* 48 x 48mm sized.
- \* Triggering whit supply voltage.
- \* Contact output for timing function (OUT).
- \* 6 Different timing modes for OUT (A, B, C, D, E, F).
- \* 6 Different timing unit selections for OUT (S,10S, M, 10M, H, 10H).
- \* Suitable for 8 pin octal or 5 screw-terminal connection.
- \* CE marked according to European Norms.

### ORDER CODE

ATSP4-K05-UV-01

**Product Basic Code**  
Panel Mounted  
Multifunction Analog Timer

**Connection Type**  
5 Pin screw-terminal K05  
8 Pin octal S08

Scale	01	02
01	0 ... 1,2	
03	0 ... 3	
12	0 ... 12	
30	0 ... 30	
60	0 ... 60	

Supply Voltage	UV	LV
90-250V AC		
24V AC/DC		

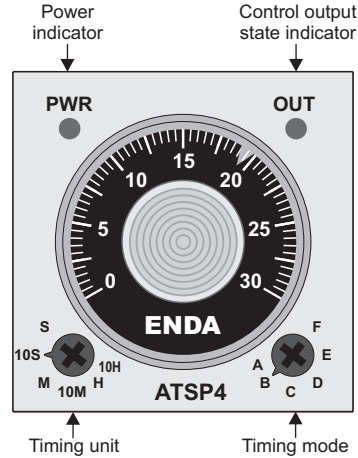

**CE** **RoHS**  
Compliant

### Connection Diagram



ENDA ATSP4 is intended for installation in control panels. Make sure that the device is used only for intended purpose. The electrical connections must be carried on by a qualified staff and must be according to the relevant locally applicable regulations. During an installation, all of the cables that are connected to the device must be free of electrical power. The device must be protected against inadmissible humidity, vibrations, severe soiling. Make sure that the operation temperature is not exceeded. All input and output lines that are not connected to the supply network must be laid out as shielded and twisted cables. These cables should not be close to the power cables or components. The shielding must be grounded on the instrument side.

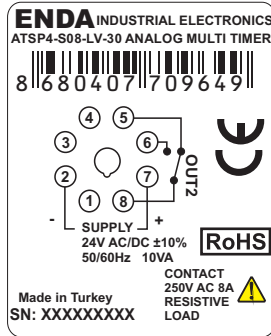
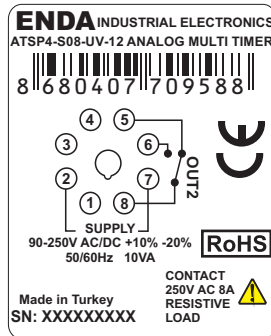
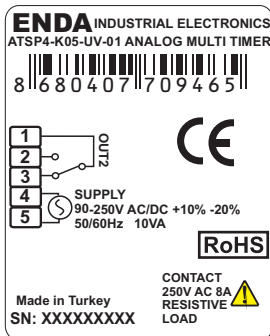

#### NOTE :

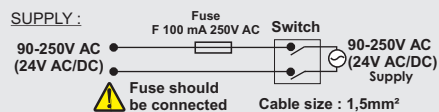

- 1) Mains supply cords shall meet the requirements of IEC 60227 or IEC 60245.
- 2) In accordance with the safety regulations, the power supply switch shall bring the identification of the relevant instrument and it should be easily accessible by the operator.

## Technical Specifications

ENVIRONMENTAL CONDITIONS	
Ambient/storage temperature	0 ... +50°C/-25 ... 70°C (There shouldn't be icing or condensation on the environment.)
Relative humidity	80% Relative humidity for temperatures up to 31°C, decreasing linearly to 50% at 40°C.
Rated pollution degree	According to EN 60529 Front panel : IP50 Rear panel : IP20
Height	Maximum 2000m
Do not use the device in locations subject to corrosive and flammable gasses.	

ELECTRICAL CHARACTERISTICS	
Supply voltage	90-250V AC, 50/60Hz or 24V AC ±%10, 50/60Hz or 24V DC ±%10
Power consumption	Maximum 10VA
Connection	8 Pin octal connector or 5 Pin screw-terminal.
Scale	0-1.2, 0-3, 0-12, 0-30 or 0-60.
Reset time	0.3 Seconds for ATP4-UV, 0.01 seconds for ATP4-LV.
Accuracy	Depending on the effect of supply voltage : max %0.2 Depending on the set value settings : max %5 Depending on the effect of temperature : max %1
EMC	EN 61326-1: 2006
Safety requirements	EN 61010-1: 2010 (pollution degree 2, over voltage category II)
Insulation test voltage	3kV AC min. 1 minute, 4,2kV DC min. 1 minute.

OUTPUTS	
Control output (OUT)	Relay: 250V AC, 8A (resistive load), NO+NC
Life expectancy for relay	Without load 30.000.000 operation; 250V AC, 8A resistive load 100.000 operation.
Control output state	OUT Led lights up when there is power at the output control, it is flashes as long as the timer is running.

CONTROL	
Timing function	A, B, C, D, E, F Modes can be selected on device.
Timing unit	Second, 10 seconds, minute, 10 minutes, hour, 10 hours units can be selected on device.

HOUSING	
Housing type	Suitable for flush-panel mounting or rail mountable 8/11 pin octal connector.
Dimensions	W48xH48xD82mm
Weight	Approx. 100g (after packing)
Enclosure material	Self extinguishing plastics
While cleaning the device, solvents (thinner, benzene, acid etc.) or corrosive materials must not be used.	

### Dimensions

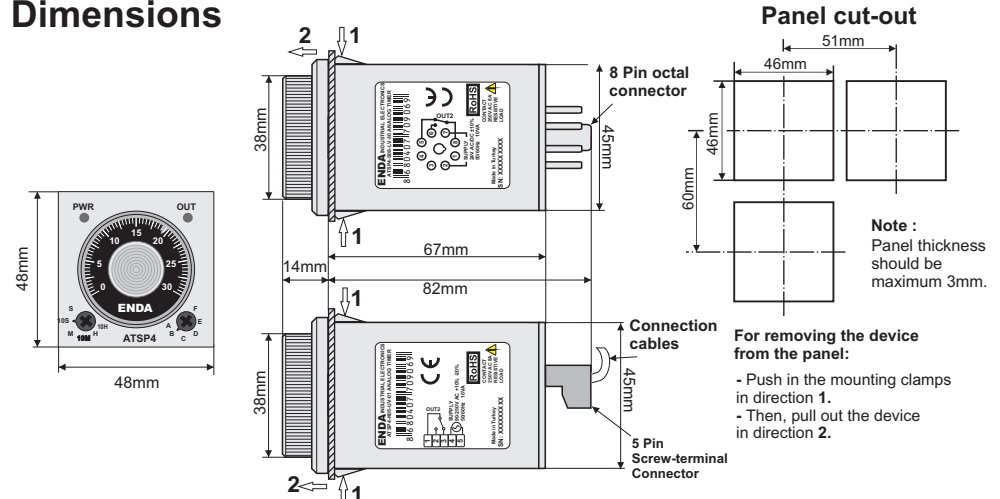



# OUTPUT CONTROL

## ATSP4-K05-xV-xx / ATSP4-S08-xV-xx

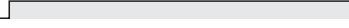
For 5 Pin screw-terminal / 8 Pin octal connection.

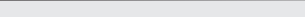
Power 

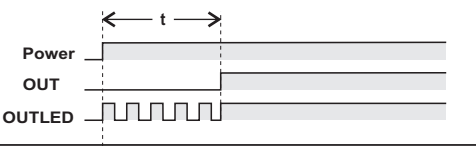
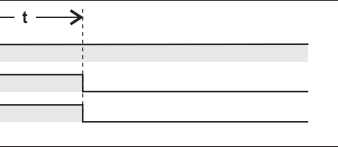
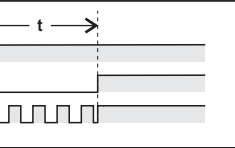
Power Led 

Mode (A, B, C, D, E, F)	Output Graphic ( t : Set Time)
<b>Mode A :</b> Relay trigger ON-Delay.	
<b>Mode B :</b> Relay trigger ON-Power.	
<b>Mode C :</b> Relay periodic trigger with power-on start	
<b>Mode D :</b> Relay periodic trigger on delay	
<b>Mode E :</b> Single puls on delay	
<b>Mode F :</b> Periodic pulse on delay	

### Statements & Descriptions

- A- Relay trigger ON-Delay.  
When Power on, end of the settled period switch ON.
- B- Relay trigger ON-Power.  
When Power on, switch immediately ON, end of the settled period switch OFF.
- C- Relay periodic trigger with power-on.  
When Power on, switch immediately ON, end of the settled period switch OFF, process continues periodically.
- D- Relay periodic trigger on delay.  
When Power on, end of the settled period switch ON, process continues periodically.
- E- Single puls on delay.  
When Power on, end of the settled period switch ON, after 0.5 sec OFF.
- F- Periodic pulse on delay.  
When Power on, end of the settled period switch OFF, after 0.5 sec OFF, process continues periodically.