



Read this document carefully before using this device. The guarantee will be expired by damaging of the device if you don't attend to the directions in the user manual. Also we don't accept any compensations for personal injury, material damage or capital disadvantages.

ENDA ETC9420 PID TEMPERATURE CONTROLLER

Thank you for choosing ENDA ETC9420 temperature controller.

- * 96 x 96mm sized.
- * Selectable sensor type.
- * Automatic calculation of PID parameters (SELF TUNE).
 - ⚠ Enter PID parameters of the system if they are known at the beginning. Otherwise, Self-Tune should be activated.
- * Soft-Start.
- * Communication via RS-485 ModBus protocol (Optional).
- * Selectable SSR or relay control output.
- * Relay output can be programmable as second alarm or control output.
- * AL1 relay output for first alarm out.
- * Selectable Heat/Cool control.
- * Input offset feature.
- * In the case of sensor failure periodical running or relay state can be selected.
- * Parameter access protection on 3 levels.
- * Programming by using keypad or Modbus.
- * CE marked according to European Norms.



R^oHS
Compliant

TECHNICAL SPECIFICATIONS

Input type	Temperature range		Accuracy
	°C	°F	
Pt 100 Resistance Thermometer EN 60751	-200...600 °C	-328... +1112°F	± 0,2% (of full scale) ± 1 digit
Pt 100 Resistance Thermometer EN 60751	-99.9...300.0°C	-99.9...+543.0°F	± 0,2% (of full scale) ± 1 digit
J (Fe-CuNi) Thermocouple EN 60584	0... 600°C	+32... +1112°F	± 0,2% (of full scale) ± 1 digit
K (NiCr-Ni) Thermocouple EN 60584	0...1200°C	+32... +2192°F	± 0,2% (of full scale) ± 1 digit
T (Cu-CuNi) Thermocouple EN 60584	0... 400°C	+32... +752°F	± 0,2% (of full scale) ± 1 digit
S (Pt/Rh-Pt) Thermocouple EN 60584	0...1600°C	+32... +2912°F	± 0,2% (of full scale) ± 1 digit
R (Pt13Rh-Pt) Thermocouple EN 60584	0...1600°C	+32... +2912°F	± 0,2% (of full scale) ± 1 digit

ENVIRONMENTAL CONDITIONS

Ambient/storage temperature	0 ... +50°C/-25... +70°C (with no icing)	
Max. Relative humidity	80% up to 31°C decreasing linearly 50% at 40°C.	
Rated pollution degree	According to EN 60529	Front panel : IP65 Rear panel : IP20
Height	Max. 2000m	
⚠ Do not use the device in locations subject to corrosive and flammable gases.		

ELECTRICAL CHARACTERISTICS

Supply	230V AC +10% -20%, 50/60Hz or 24V AC ±10%, 50/60Hz.
Power consumption	Max. 7VA
Wiring	2.5mm ² screw-terminal connections
Line resistance	For thermocouple max.100ohm, for 3 wired Pt 100 max. 20ohm
Data retention	EEPROM (minimum 10 years)
EMC	EN 61326-1: 1997, A1: 1998, A2: 2001 (Performance criterion B for standard EN 61000-4-3)
Safety requirements	EN 61010-1: 2001 (Pollution degree 2, overvoltage category II)

OUTPUTS

CONT./AL2	Relay : 250V AC, 2A (for resistive load), NO/NC. Selectable as Control or Alarm2 output.
AL1	Relay : 250V AC, 2A (for resistive load), NO/NC selectable. (Alarm1 output).
SSR out	Selectable logic control output. (Max 12V 20mA)
Life expectancy for relay	Mechanical 30.000.000 operation; Electrical 300.000 operation

CONTROL

Control type	Single set-point and alarm control
Control algorithm	On-Off / P, PI, PD, PID (selectable)
A/D converter	15 bits
Sampling time	500ms
Proportional band	Adjustable between 0% and 100%. If Pb=0%, On-Off control is selected.
Integral time	Adjustable between 0.0 and 100.0 minutes
Derivative time	Adjustable between 0.00 and 25.00 minutes
Control period	Adjustable between 1 and 250 seconds
Hysteresis	Adjustable between 1 and 50°C/F
Output power	The ratio of power at a set point can be adjusted between 0% and 100%

HOUSING

Housing type	Suitable for flush-panel mounting according to DIN 43 700.
Dimensions	W96xH96xD50mm
Weight	Approx. 410g (after packing)
Enclosure material	Self extinguishing plastics.



While cleaning the device, solvents (thinner, benzene, acid etc.) or corrosive materials must not be used.

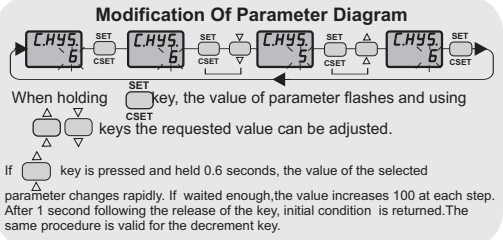
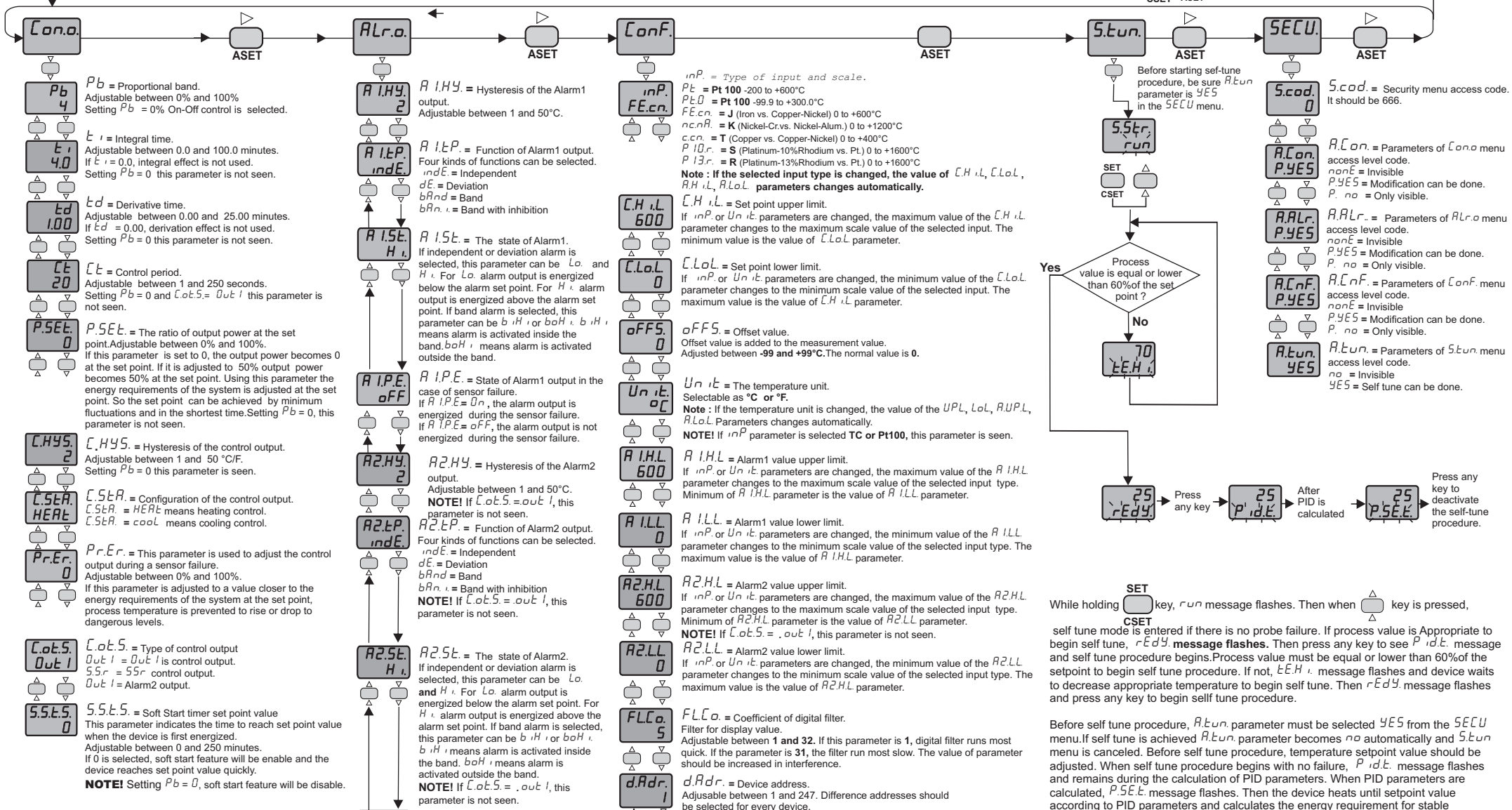
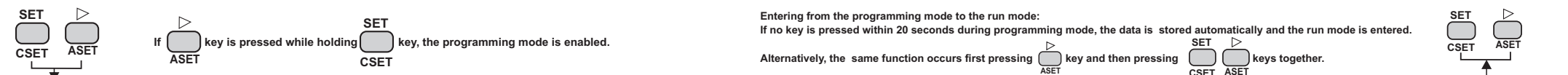

TERMS

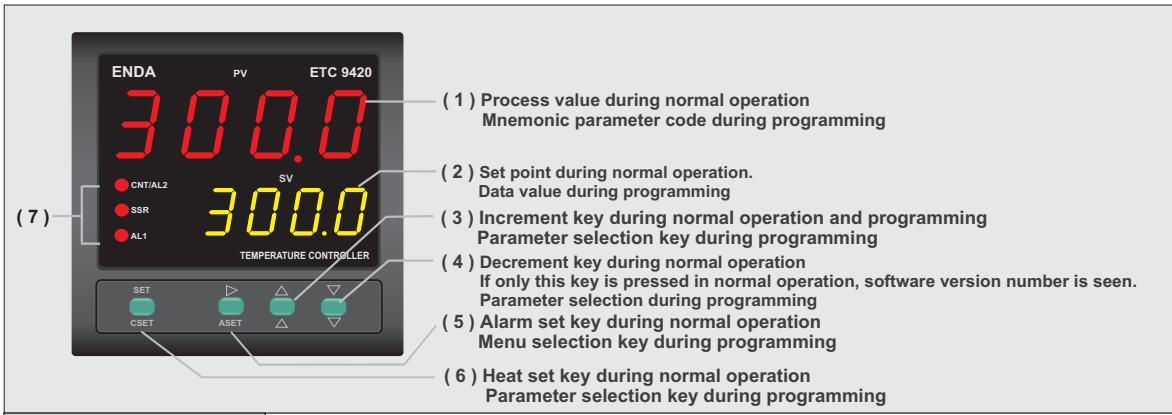

(1) PV display	4 digits 7 segment red LED
(2) SV display	4 digits 7 segment yellow LED
Character heights	PV display : 20 mm
	SV display : 14 mm
(3),(4),(5),(6) Keypad	Micro switch
(7) State indicator	3 red LEDs for Control, Alarm1 and SSR outputs

ALARM1 AND ALARM2 OUTPUT TYPES

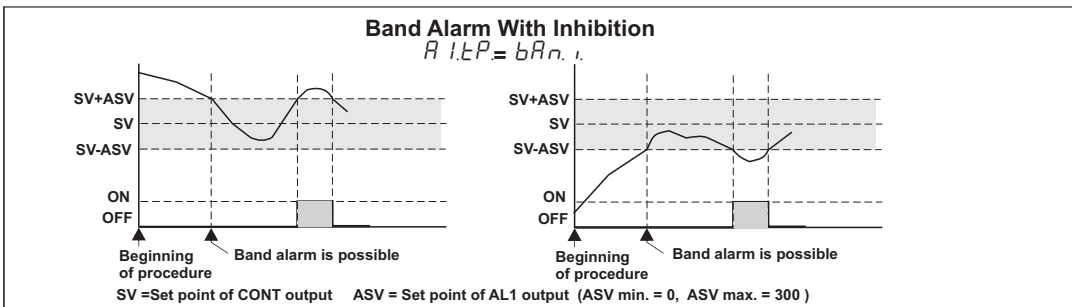
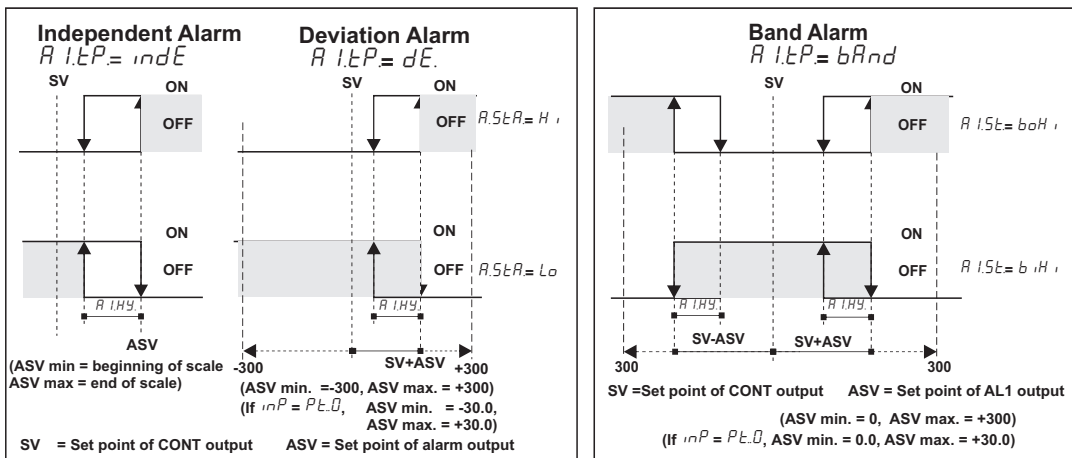

MODIFICATION OF CONTROL AND ALARM SET POINTS

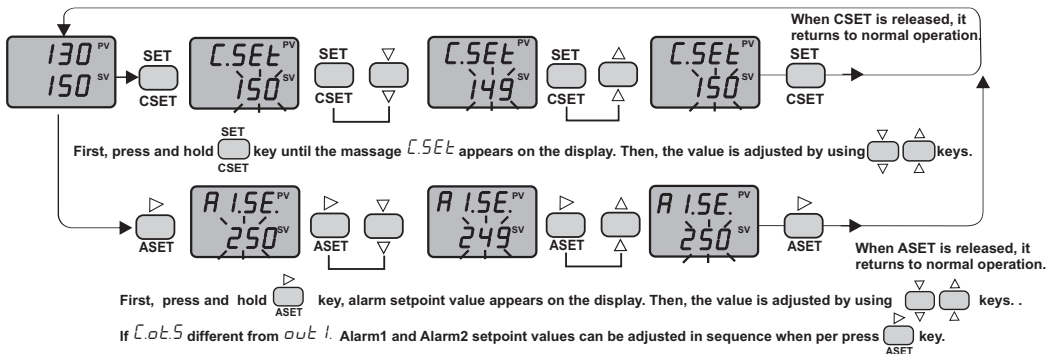

NOTE: The maximum of **C.SET** is the value of **CHiL** parameter and the minimum of it is the value of **CLoL** parameter.
If independent alarm is selected, **A1.SET** and **A2.SET** values can be adjusted between the limits of the full scale.
If deviation alarm is selected, **A1.SET** and **A2.SET** values can be adjusted between -300 and +300.
If band alarm is selected, **A1.SET** and **A2.SET** values can be adjusted between 0 and +300.

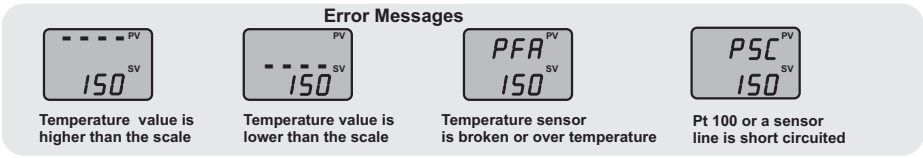

DIMENSIONS

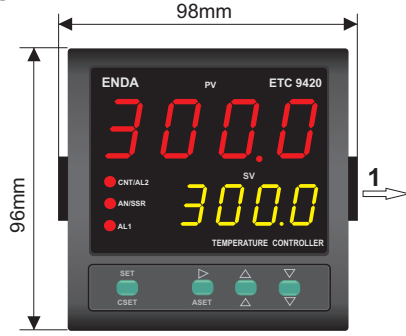

For removing the device from the panel:
-While pressing both side of the device in direction 1, push it in direction 2.

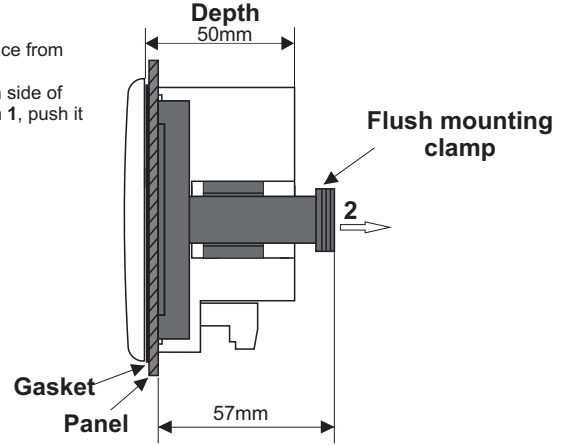

Panel cut-out

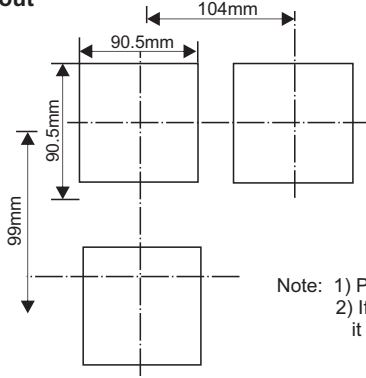

Note: 1) Panel thickness should be maximum 10mm.
2) If there is no 60mm free space at back side of the device, it would be difficult to remove it from the panel.

CONNECTION DIAGRAM



ENDA ETC9420 is intended for installation in control panels. Make sure that the device is used only for intended purpose. The shielding must be grounded on the instrument side. During an installation, all of the cables that are connected to the device must be free of energy. The device must be protected against inadmissible humidity, vibrations, severe soiling and make sure that the operation temperature is not exceeded. All input and output lines that are not connected to the supply network must be laid out as shielded and twisted cables. These cables should not be close to the power cables or components. The installation and electrical connections must be carried on by a qualified staff and must be according to the relevant locally applicable regulations.

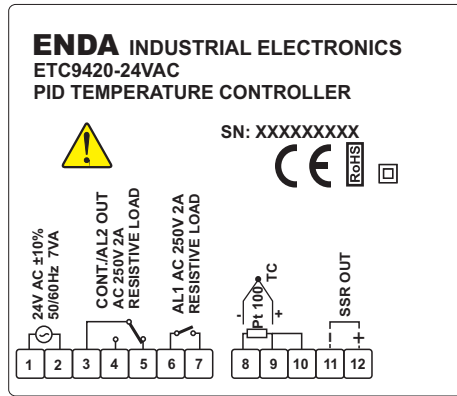
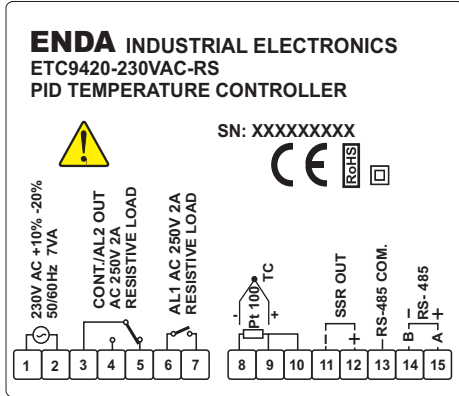

Logic output of the instrument is not electrically insulated from the internal circuits. Therefore, when using a grounding thermocouple, do not connect the logic output terminals to the ground.

Note 1) Mains supply cords shall meet the requirements of IEC 60227 or IEC 60245.
2) In accordance with the safety regulations, the power supply switch shall bring the identification of the relevant instrument and it should be easily accessible by the operator.

Holding screw
0.4-0.5Nm

NOTE :

SUPPLY :

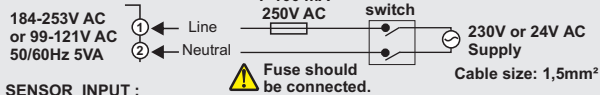

SENSOR INPUT :

For J-K-T-S-R type thermocouple :
Use suitable compensation cables. Don't use jointed cables. Pay attention to the polarities of the thermocouple cables as shown in the figure right are connected to the .

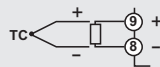

For resistance thermometer :
When 2 wired Pt 100 is used, terminals 9 and 10 must be short circuited.

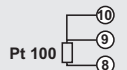

Order Code : ETC9420-□□□□□□-□□
1 2

1- Supply Voltage

230VAC...230V AC
24VAC.....24V AC
SM.....9-30V DC / 7-24V AC

2- Modbus Option

RS.....RS-485 Modbus communication
None....Don't support RS-485 Modbus communication