

PLC Series Operating Manual

This operating manual contains the information about the usage and safety of GMTCNT modules.



! Please read this document carefully before product. The user has the responsibility of the damages and accidents that occur because of not sticking to the warnings in the operating manual. In this kind of situations, the device is out of guarantee. !

Important Safety Instructions

Priority Considerations:



- The device must be plugged of before the links between the cables are done.
- The cabling should be done according to the diagrams. Otherwise, PLC module can get damage or may not do it's job.
- Don't touch to the device while there is energy in the module terminals.
- Installing or taking off extension modules to the PLC while there is energy causes damage.
- The device is in EN standards and CE approved.

Montage Rules

- The user must be observed in the process of montage of the modules. Otherwise, the work of the device can be affected or can cause permanent damage.
- There must be 50 mm between the device and the surface of the panel that it has been planted and the facts about the air condition in the place should be applied.
- The enviromental conditions must be suitable with the heat and moisture limits that had been given in the technical specifications.



**RoHS
Compliant**

<http://www.gmtcontrol.com>

3

PLC CPU MODULES – General Specification

PLC CPU modules are in 2 main groups, 5 series. These have the qualities that are told in the table below.

GLC-196R	9 digital inputs 20 kHz counter, 6 relay outputs
GLC-196T	9 digital inputs 20 kHz counter, 6 transistor outputs (3 channels 20kHz)
GLC-296R	9 digital inputs 50 kHz counter, 6 relay outputs, analog input analog output
GLC-296T	9 digital inputs 50 kHz counter, 6 transistor outputs (3 channels 100 kHz), analog input, analog output
GLC-396R	9 digital inputs 50 kHz counter, 6 relay outputs, analog input, analog output, WMI, RTC, ModBus TCP
GLC-396T	9 digital inputs 50 kHz counter, 6 transistor outputs (3 channels 100 kHz), analog input, analog output, WMI, RTC, ModBus TCP
GLC-496R	9 digital inputs 200 kHz counter, 6 relay outputs, analog input, analog output, WMI, RTC, ModBus TCP
GLC-496T	9 digital inputs 200 kHz counter, 6 transistor outputs (3 channels 500 kHz), analog input, analog output, WMI, RTC, ModBus TCP
GLC-596R.net	9 digital inputs 50 kHz counter, 6 relay outputs, analog input, analog output, WMI, RTC, ModBus TCP, possibility to programme with Microsoft.net frameWork
GLC-596T.net	9 digital inputs 50 kHz counter, 6 transistor outputs (3 channels 100 kHz), analog input, analog output, WMI, RTC, ModBus TCP, possibility to programme with Microsoft.net frameWork

PLC CPU MODULES – Technical Specification

Device description: CPU modules are the modules that collect data from the extension modules that are connected to it and controls in the PLC series. It can work without needing another device.

I/O Capacity: Has 15 or 17 I/O capacity depending on the model. It is possible to have up to 274 I/O capacity by plugging extension modules to the PLC configuration. It is possible to plug up to 16 extension modules.

Communication ports: All models have got Ethernet port, RS 232 and RS485 ports.

- Ethernet port: Ethernet port can be used for both programming or connecting to network. This port supports MODBUS TCP Slave protocol. It is possible to change or watch the programme of the PLC by network with WMI technology.
- RS232 port: PLC can communicate with 3rd party smart devices with this port. This port supports MODBUS RTU and ASCII protocol.
- RS485 port: This port supports MODBUS RTU and ASCII protocol. PLC can be used in multidrop network system with RS485.
- USB port: Can connect to PC by USB port. Data logging is supported by external memory disk.

Real Time Clock (RTC): Provides doing operation according to time and date to the PLC. CPU keeps the information of the time and the date when the energy was gone.

Usage: PLC CPU can work alone without needing any other device. CPU process speed and program capacity is same in all series. Works with 24VDC power. Montage is ON DIN rail and is easy to cable with the it's construction with clips.

Programming: PLC can be programmed with GMTSoft ladder editor. GMTSoft editor can be downloaded from <http://gmtcnt.com/en/downloads/software-drivers.html> link which is on our website. The connection between GMTSoft programme and the PLC which uploads the programme is done by the methods below.

- The connection is made by standard CAT5 ethernet cable. Can be used directly between the ethernet ports of the PLC and PC.
- PLC ethernet cable can connect to the HUBs or switches that the PC is connected to. If there is more than one PLC on the web, the PLC should be chosen and is chosen from the list of MAC addresses. This address also remains on the tag of the PLC.
- USB Mini-B cable type is used as USB cable.

5

PLC CPU MODULES – General Specification

Specifaction	Section	Remarks
General	Supply	24VDC, +-%15 tolerance
	Power	Max 3W @ 24 VDC
	CPU Process speed	12ns/command, 220 MIPS Arm CortexM4F
	Programme language	GMTSoft editor, ladder method
	Programme Capacity	64kB Ladder compiled
	RTC (Real Time Clock)	Possibility to programme the according to time and date
	Operations	Logical, mathematical, communication, fast counter, fast pulse outputs, timers and special function blocks
Communication Ports	Ethernet port	Programming by 100MB ethernet port, setting up link, MODBUS TCP Slave help, opportunity to connect to the device by the net with WMI technology.
	USB port	Opportunity for making connection to PC by USB port, making auto-saves and creating folders with the help of external disc connection.
	RS232	4800...115200 bp speed support by ASCII or MODBUS RTU protocol
	RS485	4800...115200 bp speed support by ASCII or MODBUS RTU protocol
Inputs/Outputs	Digital outputs	6 24VDC@300Ma transistor output (max output frequency for fast pulse outputs is 500kHz) / 6 Relay outputs 230VAC@5A
	Digital inputs	9 24VDC pnp/npn inputs, 3 double phase encoder can be connected, reading frequency is max. 200kHz.
	Analog input	0...10VDC/0...20mA analog input, 12 bit resolution
	Analog output	0...20mA analog output, 14 bit resolution
Memory area	Integer variables	1024 adresses 32 bit signed, 512 adresses 16 bit unsigned
	Decimally variables	1024 adresses 32 bit variables
	Counters	256 adresses 32 bit increasing/decreasing counter blocks
	Timers	128 adresses, 4 type timers with 1ms resolution (32 bit)
	System variables	128 adresses 32 bit signed
	Virtual bits	1024 adresses
	System bits	256 adresses
Enviromental Conditions	Heat	0...+50C working gap (without icing)
	Humidity	5...95%Rh moisture working gap
	Enviroment	Places that doesn't contain burnable or abradant gasses

PLC CPU MODULES – Mechanical Specification

Mechanical Qualities: The device is DIN rail mounted. If there are any extension modules on the configuration, the device should be mounted to the rail after the devices are mounted to each other. Module is locked on the rail by it's clip. The construction is showed below:

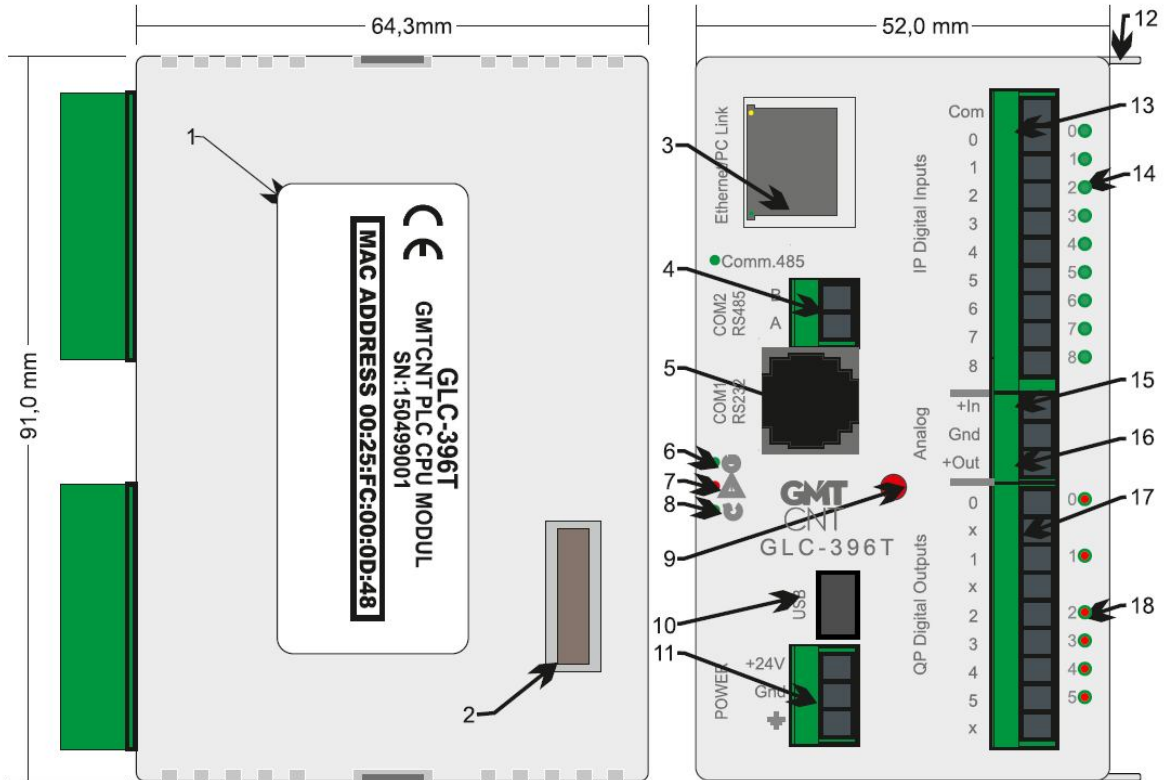

1	PLC label	10	USB port
2	Extention Module BUS connection port	11	Supply clip
3	100Mb ethernet port	12	Extention module mounting clip
4	Rs485	13	Digital input clip block
5	Rs232	14	Digital input status leds
6	PLC power led	15	Analog input clip
7	PLC fault led	16	Analog output clip
8	PLC run led	17	Digital output clip block
9	Reset button	18	Digital output status leds

7

Led Status , Digital (On/Off) output connection

Led status

Power led: Led is on when 24VDC exists.

1) Fault led: Is not supposed to be on in normally.

- Gets on for only 0.5 seconds when the energy is first given to the device.
- If the module configuration is wrong (matching error), gets on and of 3 times periodically.

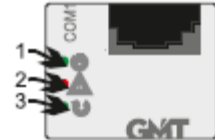

2) PLC status led:

- Keeps getting on for 1 second and getting of for 1 second.
- Keeps getting on for 0.25 seconds and getting of for 0.25 seconds if the programme is running.

Digital outputs: Are the On/Off outputs on the CPU. Can be in relay or transistor type according to the CPU model. Are commended by the QP operands in the programme.

GLC-X96R Series output wiring

Outputs are 230VAC@5A relays. Relay outputs commons are divided into three groups. QP(0) and QP(1) has their own commons, and QP(2), QP(3), QP(4) and QP(5) as a group ha another common. Because the relays work as dry contacts, unless the flow limit is passed over, it is available both with AC or DC connections.

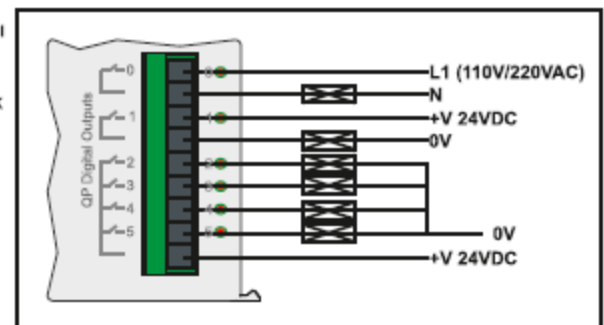

- Switching frequency must be at 100Hz max.
- Max. Voltage value is 270VAC/125VDC.
- There is a status led for each output.

GLC-X96T Series output wiring

Outputs are pnp transistors. Can be contacted to relay, contactor, solenoid valve rollers directly.

- Max. Switching frequency is 3kHz.
- 24 VDC@300mA output.
- Protection for short circuit is available.

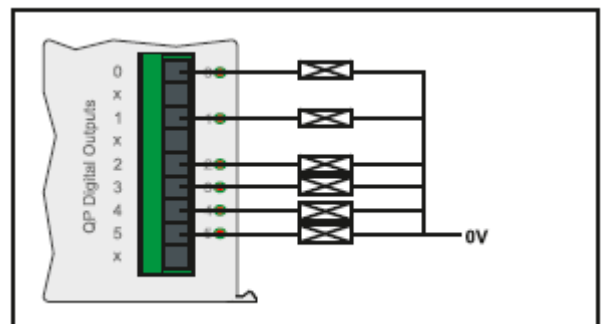

Led Status , Digital (On/Off) input connection

Digital Inputs

Digital inputs are the On/Off inputs which are on CPU. Input type can be pnp or npn. Indicating speed is 500kHz. Is sensitive to short pulse (0,15 ms amplitude) inputs. The level of sensitivity can be increased by the filters part in GMTSoft editor. Common point (Gnd) is separated from the CPU chassis and is isolated with optocoupler.

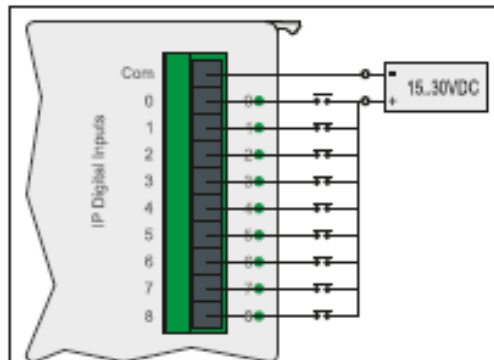
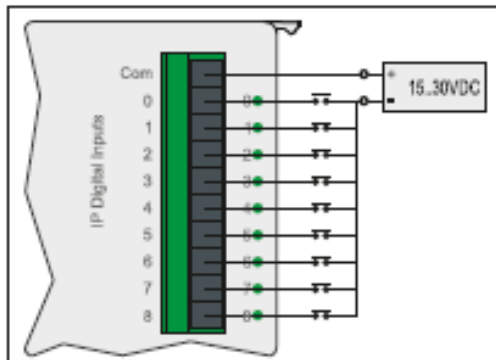

npn connection

pnp connection

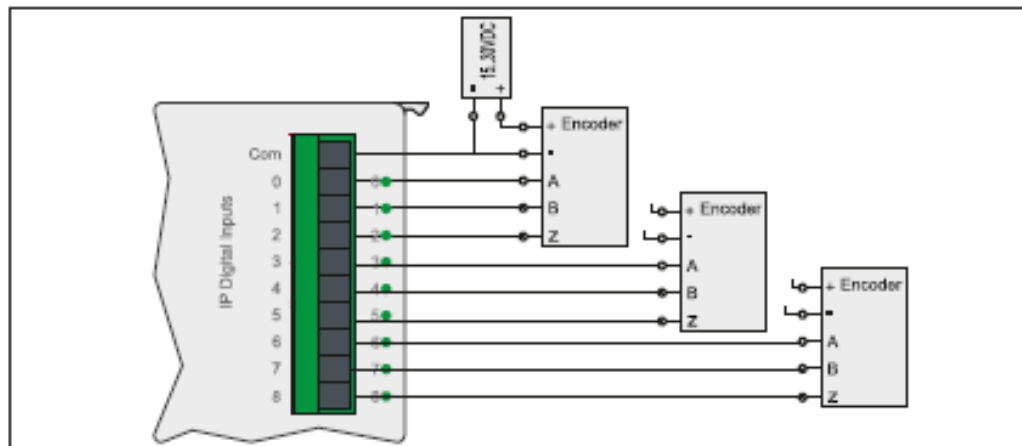

Encoder Connection

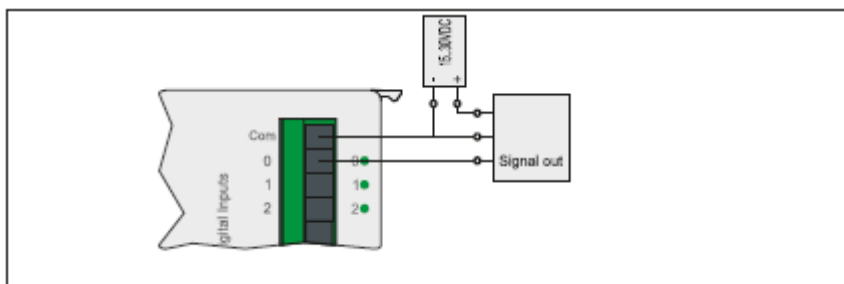

Analog Input and Output wiring

The proportional outputs and inputs on the PLC CPU. Input types are 0-10V DC and 0-20mA DC. Output type is 0-20mA DC. Can be turned to 0-10VDC using 500 Ohm resistance if required.

Analog input value is read linearly between 0...4095 and read from the SI[1] address in PLC. Repetition speed is the same with ladder scanning speed. Type is chosen by typing 0 or 1 to SB[6] register's opening value.

Analog output value is written in SI[0] address in the PLC. Produces signals that are equaled to 0...16383 value linearly. Repetition speed is the same with ladder scanning speed.

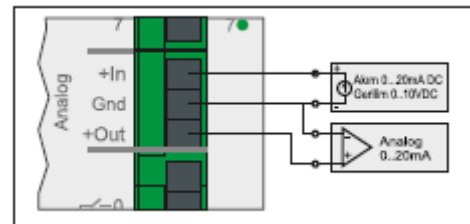

Ethernet Port

The reasons of using the ethernet port that is on th CPU,

- Programming: Can be used as the port that the programme is uploaded from the GMTSoft editor and observed or changed.
- Can connect to SCADA or smart devices in MODBUS TCP Slave mode.(GLC396)
- Programme can be uploaded to the PLC and can be observed by the internet with our WMI technology. (GLC396)
- PLC can also email the producing quantity, alarm and similar varieties of situations rather than the automation in the system in the adjusted time.

Ethernet port connects the PLC directly to the PC or the network with standard CAT5 cable.

COM1/RS232 connection

RJ11 connection jack is used. Can be used by providing serial port connection that can be defined by any ASCII protocol or with the help MODBUS RTU protocol that remains ready. The diagram which is at the right is the pin expansion of connection jack.

COM2/RS485 connection

It is possible to make RS485 network connection by a connection with connector. Communication to 255 devices using other PLC or third party devices is provided by MODBUS RTU protocol.

